

Cam Trays and Cams

Cams for mechanical single and multiple position switches

Type	BNN 520-81-S-__
	for switches with switch position spacing 8 mm or 10 mm
	For use with BNL 5304-080-... or
	BNL 5306/5308-100-...

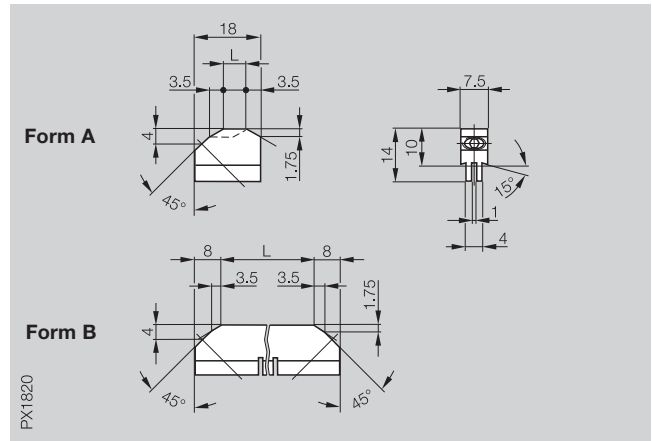

Ordering code	

Form A	L
BNN 520-81-S-0	0
BNN 520-81-S-6,5	6,5

Ordering code	

Form B	L
BNN 520-81-S-20	20
BNN 520-81-S-40	40
BNN 520-81-S-60	60
BNN 520-81-S-80	80
BNN 520-81-S-145	145

Dimensions in mm

L = Length of switching surface. Additional lengths on request.

Material: Steel with hardened and burnished surface.

Mounting possibilities for cams **Note!**

- BNN 520-UA/UB
When a set screw is tightened, the cam is clamped firmly in the slot.
 - BNN 520-81-S
When a set screw is tightened, the lower part of the cam is spread apart and the cam held firmly in place.
 - BNN 520-TA/TB
When a clamping nut is tightened, the cam is clamped firmly in the T-slot.
- Cams for safety switch positions must be installed to fit.
- A tight connection such as is necessary for safety switch positions can be made by the customer with our cams using screws, pins or by welding.

BNN 520-UA-__ , BNN 520-UB-__ per DIN 69639
for switches with switch position spacing **12 mm** and **16 mm**
For use with BNL 5304/5307-120/160-...

BNN 520-TA-__ , BNN 520-TB-__ per DIN 69639
for switches with switch position spacing **12 mm** and **16 mm**
For use with BNL 5310-120-...

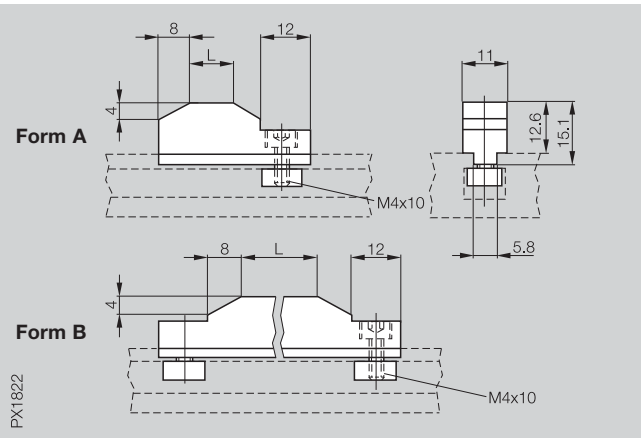
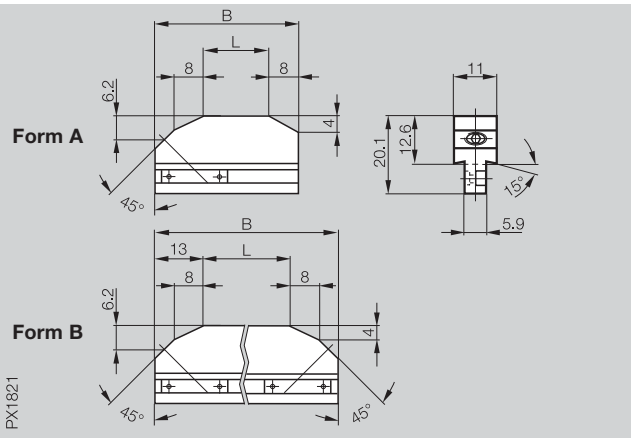

Form A	B	L
BNN 520-UA-0	21	0
BNN 520-UA-4	25	4
BNN 520-UA-10	31	10
BNN 520-UA-16	37	16

Form A	L
BNN 520-TA-0	0
BNN 520-TA-4	4
BNN 520-TA-10	10
BNN 520-TA-16	16

Form B	B	L
BNN 520-UB-25	51	25
BNN 520-UB-40	66	40
BNN 520-UB-63	89	63
BNN 520-UB-100	126	100
BNN 520-UB-120	146	120
BNN 520-UB-150	176	150
BNN 520-UB-200	226	200
BNN 520-UB-250	276	250
BNN 520-UB-300	326	300
BNN 520-UB-400	426	400

Form B	L
BNN 520-TB-25	25
BNN 520-TB-40	40
BNN 520-TB-63	63
BNN 520-TB-100	100

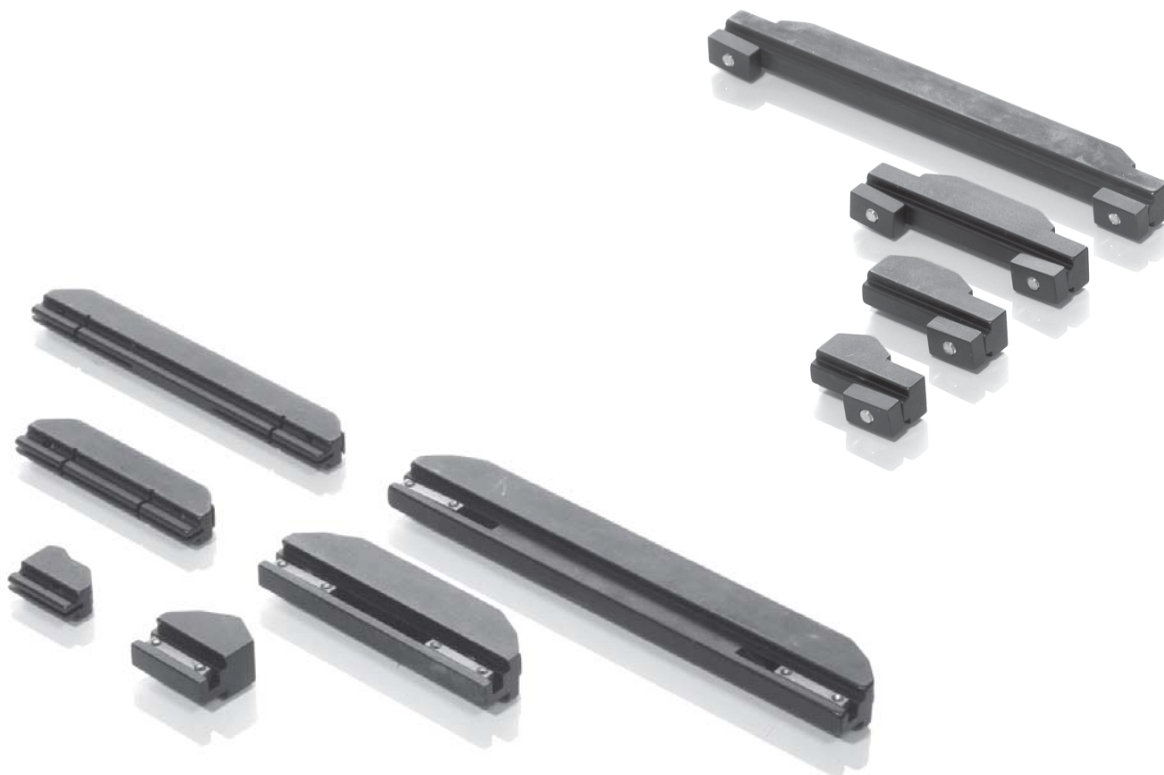

Mounting possibilities for cams

- BEN 516-13
When a set screw is tightened, the cam is clamped firmly in a T-slot of the cam tray.
- BEN 516-14/19
When a set screw is tightened, the cam is clamped firmly in a U-shaped slot of the cam tray.

Note!

Cams for safety switch positions must be installed to fit.

A tight connection such as is necessary for safety switch positions can be made by the customer with our cams using screws, pins or by welding.

Type	

Ordering code	

Ordering code	

Dimensions in mm

L = Length of switching surface.
Additional lengths on request.

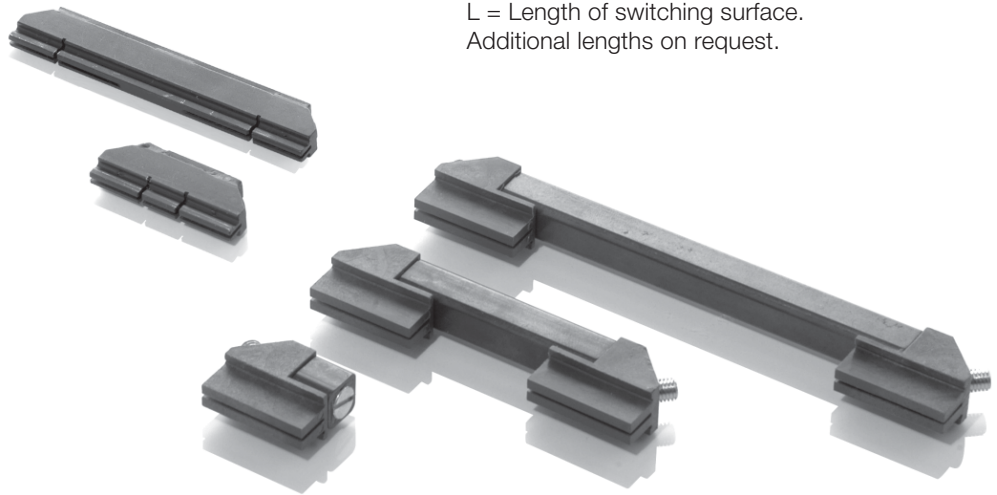

Cam Trays and Cams

Cams for inductive single and multiple position switches

BEN 516-19

For switches with switch position spacing
8 mm and 10 mm
For use with BNL 5304-080-...

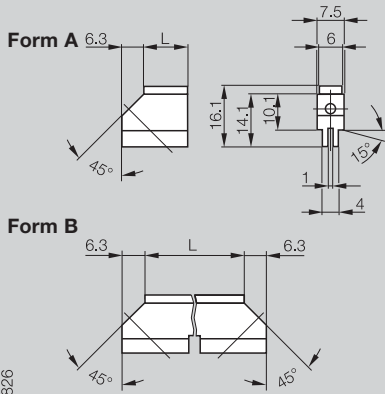

PX1826

BEN 516-14

For switches with switch position spacing
12 mm and 16 mm
For use with BNL 5304/5307-120/160-...

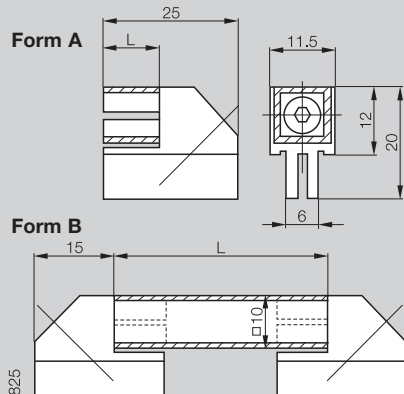

PX1825

BEN 516-13

For switches with switch position spacing
12 mm and 16 mm
For use with BNL 5310-120-...

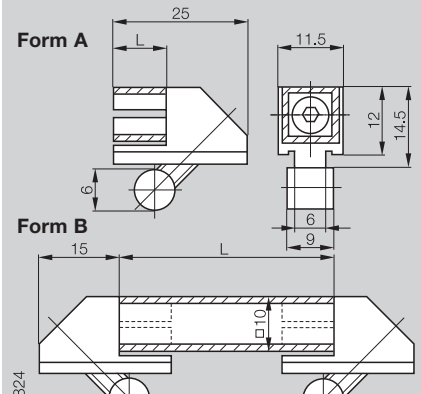

PX1824

Form A	L
BEN 516-19-10	10
BEN 516-19-15	15

Form A	L
BEN 516-14-10	10
BEN 516-14-20	20

Form A	L
BEN 516-13-10	10
BEN 516-13-20	20

Form B	L
BEN 516-19-20	20
BEN 516-19-30	30
BEN 516-19-40	40
BEN 516-19-50	50
BEN 516-19-60	60
BEN 516-19-80	80
BEN 516-19-100	100
BEN 516-19-120	120

Form B	L
BEN 516-14-30	30
BEN 516-14-50	50
BEN 516-14-100	100
BEN 516-14-120	120
BEN 516-14-140	140
BEN 516-14-160	160
BEN 516-14-180	180
BEN 516-14-200	200

Form B	L
BEN 516-13-30	30
BEN 516-13-50	50
BEN 516-13-100	100
BEN 516-13-120	120
BEN 516-13-140	140
BEN 516-13-160	160
BEN 516-13-180	180
BEN 516-13-200	200

Material: Steel with burnished surface.

Material: Steel damping element with burnished surface and base made of PA 6.6.

Material: Steel damping element with burnished surface and base made of PA 6.6.

5.2

